

# The Dragonflyre

**Newsletter for the Barony of Vatavia**



---

**First Quarter 2021**

**A.S. LV**

**[www.baronyofvatavia.org](http://www.baronyofvatavia.org)**

---

## TABLE OF CONTENTS:

Baronage, Officers, Champions, Credits	Page 1
Letter from Our King and Queen	Page 2
Letter from Our Baron and Baroness	Page 3
Officers' Letters	Pages 4-5
Officers' Meeting Minutes	Pages 6-7
Kingdom Events/Baronage Gathering	Page 8
Article: Catapults and Trebuchets	Pages 9-10
Vatavian Arts & Sciences	Pages 11-12
Medieval Olympics	Page 13
Calendars	Pages 14-16

Fonts: Matura MT Script Capitals, Britannic Bold, Arial, Lucida Calligraphy,

## CREDITS:

Chronicler: Heid Botkin (SKA Lady Heidi Anne Draper)  
Proofreader: Sherri Moreno (SKA Mistress Sorcha O'Riain)  
Cover: Painted Backdrop © 2021 Benjamin Rogers  
& Page 13 (SKA Matthius Worcestershire) Used with permission  
Page 9-10 Article: *Catapults and Trebuchets* and artwork © 2021 Mary Day  
(SKA HE Marie Chantel Delaire ) Used with permission  
Page 11 Tablet Weaving © 2021 MKA Amy Groom-Dyke Used with permission  
Page 11 Spinning Wool © 2021 Heidi Botkin (SKA Lady Heidi Anne Draper)  
Used with Permission  
Page 12 Bobbin Lace Pillow © 2021 Jayme Jones  
(SKA Lady Margaret MacKenzie) Used with permission  
Page 13 Painted Backdrop ©2021 Tammy Miller (SKA Berke Chinua)  
Used with permission  
Page 14 Painted Backdrop ©2021 Kristina Griffith  
(SKA HE Genevieve de Chambery) Used with permission

## VATAVIAN BARONAGE

**Baron Lawrence Taillefer the Leech** (Larry Bumgardner)

baron@baronyofvatavia.org

**Baroness Genevieve de Chambrey** (Kristina Griffith)

baroness@baronyofvatavia.org

## VATAVIAN OFFICERS

**Seneschal:** Lord Robert Steven MacLaren

[SKA Robert The Scot] (Robert Botkin)

seneschal@baronyofvatavia.org | 620-474-3515

**Castellan:** Master Johann Steinarsson (Jay Reynolds)

chatalainebaronyofvatavia.org

**Demo Coordinator:** HE Marie Chantel Delaire (Mary Day)

democoordinator@baronyofvatavia.org | 316-685-6165

**Historian:** HL Thomas Bacon (David Moreno)

historian@baronyofvatavia.org | 316-685-1182

**Caltrop Pursuivant:** HE Zoe Mikre

(Lynne Ahlgren) herald@baronyofvatavia.org

**Exchequer:** Lord Konrad von Roth (Kurt Jones)

exchequer@baronyofvatavia.org

**Arts & Sciences Minister:** Lady Alia Martialis

(Aimee Moisa) artsandsciences@baronyofvatavia.org

**Knight Marshal:** Lord Brynjolfir (Brynki) Falkason

(Josh Thompson) knightmarshal@baronyofvatavia.org

**Deputy Knight Marshal:** Sir Wulfric Tyrell

(Alan Horn) deputyknightmarshal@baronyofvatavia.org

**Archer Marshal:** Lady Heidi Anne Draper (Heidi Botkin)

archermarshal@baronyofvatavia.org

**Chronicler:** Lady Heidi Anne Draper (Heidi Botkin)

chronicler@baronyofvatavia.org | 620-474-5097

215 West 12th Ave, Hutchinson, Ks 67501

**Deputy Chronicler:** Matthais Worcestershire

(Benjamin Rogers) StPioB.Rogers@gmail.com

deputychronicler@baronyofvatavia.org

**Web Minister:** Lord Hieronymous (Lancelot Mills)

webminister@baronyofvatavia.org

**Property Minister:** Lord Robert The Scott (Robert Botkin)

620-474-3515

**Minister of Youth:** Lady Fujihara Murasaki

(Jeo Bondurant) Text 307-630-5017

## BARONIAL CHAMPIONS

**Borec** (Armored Combat) Lord Erik Tokesson

**Obrance** (Cut & Thrust) Lord Oyrikr Radulfsson

**Lucisnik** (Archery) Master Johann Steinarsson

**Zevack** (Bardic) Lord Samuel Strange fellow

**Estradni Umelec** (Arts & Sciences) HE Wulfric Tyrrell

*Calontir,*

*As the weather turns warmer and the news begins to brighten regarding the pandemic, we know that the urge to meet and gather with friends to pursue the endeavors of the SCA is strong. After a year of near isolation, We feel it too. Nothing would make us happier than to see you all and celebrate the turning of the seasons.*

*For now, however, we ask you to continue to exercise the patience you have shown Us so far. The Society moratorium on Events remains in place at least through the end of May this year.*

*Her Majesty and I continue to look at options and timing to allow local outdoor meetings resume but have not yet come to any conclusions. For the good of the greatest number of Our populace much of these decisions rest on the velocity and availability of vaccinations across the Kingdom and their impact on infection rates. Though many Calontiri will not be eligible for several more months, We hope to be able to share good news with you in this regard soon. In the meantime, these hopeful tidings do not mean that our vigilance can slacken. Carelessness now, after all we have given up, at verge of victory, will be detrimental to all Calontiri.*

*Ever Vigilant*

*Lucian and Tamar*

*Dearest Friends,*

*As we emerge from the darkness of our Winter of Discontent into the dawning of Spring, it ushers in hope for new opportunities, change, growth, gatherings and renewal. The next few months may be the most difficult yet, for temptations are abundant. We must stand strong and stay the course to see this through to an acceptable conclusion. We have sacrificed so much and seen the loss of so many this year, in order to keep our friends and loved ones safe. It would be tragic to see an upswing in illnesses right at this crucial tipping point. We are so close. Thank you for your patience and enduring, stalwart fortitude throughout this year. It is truly inspiring to see the populace encouraging each other, supporting each other and helping each other grow. Please continue to build each other up, It is so very easy to see the negative in times of stress and disappointment. We will not falter and we will not fail! Please continue to wash your hands, wear a mask and social distance. Vaccines are becoming more widely available. Each day we gain more momentum as more people are vaccinated. We can not guess when we will be face to face again, but we are looking forward to the day when we can once again embrace friends and loved ones.*

*In preparation for the time when we can once again meet. We are forming a committee to help plan and execute a ReUnion Celebration for the Barony and surrounding area to be held at a time yet to be determined. This should be a joyous salute, a party to remember! If you would like to be a part of this committee send a message to either Genevieve or Robert. We need your input! Any suggestions or Ideas would be greatly appreciated and all volunteers are welcome.*

*You are always in our hearts and minds,  
In faithful service and love,*

*Lawrence and Genevieve  
Baron & Baroness  
Barony of Vatavia, Kingdom of Calontir*

## FROM THE SENESCHAL

Greetings Vatavia!

I hope everyone is doing well and are staying safe from everything that is going on. As you all know we are limited on what we can do until 31 May 2021. We are still getting together on zoom every Wednesday around 7 pm. Check the Herald (newsletter) that their Excellencies put out pretty much every week. I try to update the Calendar as soon as I can after each of their Posts. You can find the Baronial Calendar at <http://www.baronyofvatavia.org/>

We are still conducting our Officer/Business meeting on zoom the first Wednesday of each month and a Populace meeting/get together on the third Wednesday of each month. Every other Wednesday you can stop by the Zoom meetings for Arts and Science classes. Even though it is not in person get together, but come on by and see old friends and hopefully make new ones.

Hope you all stay safe! If you are needing anything, please message me, or send me an email of your concerns or needs and I will get back to you.

Yours in Service

Robert Steven MacLaren

Aka Robert the Scot

## FROM THE CASTELLAN

From the Castellan

Good gentles of Vatavia,

I know these months of the pandemic have been hard on us all. I wish that I could greet every new member of our Barony in person - but that day will come soon enough. In the meantime, our Barony is doing its best to keep interest afloat with Zoom classes and gatherings, and I do urge you all to come and check it out. We have had quite an assortment of online learning to choose from!

I would also like to remind you that if anyone has a question about what we have planned, please feel free to contact me at [chatelaine@baronyofvatavia.org](mailto:chatelaine@baronyofvatavia.org), and I promise that if I can't answer your questions, I will help you find the person who can.

Ever in service to the Barony, our Populace, and The Dream,

Kennari Johann

## FROM THE EXCHEQUER

Good day to all.

Here is where the Barony sits on available monies as of the end of February 2021. We currently have a balance of 16,430.86 in the bank. If there are any questions I can be reached at the Baronial website email [exchequer@baronyofvatavia.org](mailto:exchequer@baronyofvatavia.org).

YIS Lord Konrad von Roth

## FROM THE PROPERTY

### MINISTER

Greetings Vataavians! Hopefully we will be able to come together here in the near future. With that in mind please look at all your Baronial property that you may have and check to see if it is still workable. If not please let me know and we can look at repairing it. When we are able to start meeting again in person, I have several projects (repairs) that I need to do and along with a project or two for the Ren-Fairs. I will be letting everyone know after we find out that we can come together and start these repairs and projects.

In Service

Robert the Scot

Property Minister

## FROM THE KNIGHT MARSHAL

With there finally being some light at the end of the covid tunnel please keep a close eye on the Kingdom and Baronial websites for when we can resume official SCA practices. In the meantime, please start moving now. Try to stretch and do some cardio to prevent the risk of injury when we return. Look over your gear now to ensure there will be no surprises when we return. I know we all greatly miss each other and SCA combat so lets all do what we can to ensure we can safely return once the restrictions are lifted.

See you all soon,

Lord Brynjólfr 'Brynki' Fálkason

## FROM THE CUT & THRUST MARSHAL

Greetings from the Cut and Thrust Marshal,

With news of the many vaccines for Covid coming out/being distributed and the lessening of restrictions from national and local guidelines we are looking in the near future to being able to have practices again. For now we need to continue to maintain our physical fitness as well as our equipment, please look over your armor for any rips or holes that need mending as well as taking apart your swords and checking for any damage or rust.

In Service,

Right Honorable William Douglas

"Ferrum numquam dormitat"

## FROM THE ARCHER

### MARSHAL

Greetings,

As the weather warms up and COVID dies down, I hope we can start gathering again soon. This is a great time to check over your archery equipment and get your arms back in shape. We will begin holding Archery Practice again as soon as it is deemed safe to do so.

I look forward to a time when we can gather together again.

YIS,

Heidi Anne Draper

## FROM THE ARTS AND SCIENCES MINISTER

Greetings Fellow Vatavians!

The cold of Winter is quickly passing and Spring is right around the corner, giving us all an opportunity to go outside and enjoy the creative inspiration that budding, blooming, buzzing, and tweeting Nature can provide. In just the last two weeks I've seen bugs and birds of all varieties and colors, squirrels and deer, flowers starting to bloom and leaves budding on the trees. I have to admit, their sudden arrival is not something I'm accustomed to coming from a place with year-round Spring and Summer, and I think the contrast to our Winter weather makes the return of Spring all the more beautiful. So I highly recommend everyone take this opportunity between rainstorms to go outside and let the beauty of nature inspire you to create something colorful with your hands. If you want suggestions or to chat about what you are working on, come join us at our monthly Maker Meet-up, held the 4th Wednesday of every month. The next one is going to be on March 24th and we'd love to have you. Maker Meet-up is an informal chat where we discuss and question and show & tell all things creative and fun. Hope to see you there!

YIS

Lady Ália Martialis

Arts & Sciences Minister

[artsandsciences@baronyofvatavia.org](mailto:artsandsciences@baronyofvatavia.org)

## FROM THE DEMO

### COORDINATOR

No demos are scheduled at this time.

## FROM THE CHRONICLER

Greeting to the populace,

As I start my adventure as your Chronicler, please be patient with me as I learn my new role. I will attempt to showcase your work as it so justly deserves, as well as allow you to share your knowledge with others.

Please feel free to send me pictures and articles to publish.

I will accept them at any time and will publish them in the next Dragonflyre.

YIS,

Heidi Anne Draper

## FROM THE MINISTER OF YOUTH

DOT GAME

Two or more players take turns adding a single horizontal or vertical line between two unjoined adjacent **dots**. A player who completes the fourth side of a 1x1 box earns one point and takes another turn. (A point is typically recorded by placing a mark that identifies the player in the box, such as an initial.)

[dot-game-printable.pdf](#)

YIS,

Lady Fujihara Murasaki

# OFFICERS' MEETING MINUTES

## OFFICERS' MEETING—January 6, 2021

### Meeting held on the Zoom Platform

14 members participated: 13 Baronage/ officers/deputies; 1 members of the populace

The calendar for 2021 is being filled with rescheduled events. Once the suspension is lifted 1 1/2 years of events have been planned and jammed into one year. Potentially Winter War Maneuvers could be in September, with Gulf having been rescheduled for October. Locally the Medieval Olympics Challenge will be a Yule log in any media to be presented at the January populace meeting.

The name proposal Tove Briandohter is at Kingdom for consideration. Arts and Sciences classes are being scheduled. One Wednesday will be scheduled for members to show what they are working on or have done. Using social media and talking to non-SCA members about our organization are future subjects. Once in person can resume hands on class series on from start to finish are proposed; i.e. from sheep to shawl. ZOOM contacts for classes and other gatherings/meetings will be posted on the web site and our other social media. The email address for the Dragonfly on line was shut down December 15<sup>th</sup>. A new mailing system is being researched.

The Exchequer reported a balance of \$16,440.86. The fourth quarter and Domesday reports will be done once the December bank statement received. The budget for 2021 was approved by the finance committee. With the current situation no expenditures, even those budgeted, will be made without prior approval. A new location for the Baronial property is needed. A possible location has been found if the current location can be used through the rest of the month. Officers are to get their inventories of Baronial property in their possession in. It is required for year end reports.

All martial activities are still suspended. Archery will possibly resume if Covid numbers and weather allow. Even if the weather does not support doing archery, thrown weapons or arrow repair could be done.

Vatavia's bid for our Coronation rotation goes in this month. It is not known at this time what Their Majesties plans for Crown and Coronation will be once the suspension is lifted. The fourth quarter reports are due with courtesy copies to the Seneschal and Baronage. The Chronicler's office is a required position for a Barony. Interested individuals should contact the Seneschal. The office is required to put out a publication each quarter.

The meeting adjourned.

## OFFICERS' MEETING—February 3, 2021

### Meeting held on the Zoom Platform

11 members participated: 10 Baronage/ officers/deputies/ champions; 1 members of the populace

This month's Medieval Olympic challenge is to produce a backdrop. These are to be presented at this month's populace meeting. Possible future challenges are for groups to produce a newcomer project or display and trebuchets have been requested. In January the Yule log challenge items were presented.

Plans are being made for the Fall Renaissance Festival to increase visibility with signage and dressing up the Dell area. Ideas from Master Vincent de Vere's presentation on recruiting and retention are being developed.

There are two Vatavian proposals in process, one at Kingdom and one at national. Classes are planned for February and March for arts and sciences. This month is embroidery. Then a guest teacher in An Tir will present on Roman garb. Additionally the last Wednesday of the month is the Maker Meet Up which is for any subject discussion and an additional opportunity to get together, an additional populace.

The Web Minister is working on resolving host issues on different pages of the Baronial site. Members not on social media are requested to get addresses in to be included on posting and Newsblasts. Members are asked to let those not on social media know. Also members are encouraged to continue to reach out and communicate with other members.

The Exchequer reported that the Domesday report for last year has been turned in. The current balance is \$16,437.86. Members are not to make any expenditures without first checking with the Exchequer. Once a new Chronicler is selected publishing software will be obtained.

Martial activities continue on hold with the suspension until June. Archery activities awaits suitable weather.

Their Excellencies added that member Sir Stephen Norfolk has been seriously ill but is better and is in good spirits. The best method for contacting him will be discussed with his family and members informed.

The deadline for applications for the position of chronicler is February 12<sup>th</sup> to allow time to become familiar with the publishing before the first quarter publishing deadline.

## OFFICERS' MEETING—March 3, 2021

### Meeting held on the Zoom Platform

12 members participated: 10 Baronage/ officers/ deputies/champions; 2 members of the populace

Vatavia will be hosting Winter War Maneuvers here February 19, 2022. The bid for Winter Coronation 2022 has been turned in but no notification has been received whether it has been accepted.

We will **not** be participating **officially** in the Spring Renaissance Festival here. Members are welcome to participate and volunteer **only** as private citizens. We are planning to be part of the Fall Festival. The Medieval Olympic Challenge for March is for local groups to produce a newcomer/ recruitment display. Containers are being built for this. The April Challenge is planned to be trebuchets.

The new Chronicler, Ly Heidi Anne Draper, was announced. Her deputy is Matthias of Worcestershire. She reminded members that all submissions, other than officer letters, need signed permission to publish. One Vatavia proposal has gone onto national for registration, Eyfriðr's badge, and will be decided in June. The Arts and Sciences Minister has arranged for a class on Roman garb. April 14<sup>th</sup> she will demo making glass beads. The monthly Maker Meet Up discussion provided some class ideas. She also encourages members to attend online presentations from outside our local group. The Castellán has reached out to past interested individuals to provide current contact and activity information.. The Web Minister is continuing to update the site content and resolve problems with the award form and Census.

The Exchequer reported a balance of \$16,434,86. A finance meeting was held after the Officers' meeting. With the return of warmer weather work on Baronial property and projects will start in preparation for the resumption of events and the Fall Renaissance Festival. Space has been offered by Their Excellencies at their residence.

Both the Cut and Thrust and Heavy Combat Marshals had no practices. It was proposed that a date be set for a meeting at an outdoor location for both fighting groups to get their gear out and prepare for the resumption of practices and events. Gear can be inspected for wear and needed repairs.

The Archer Marshal tentatively plans to resume practice on March 14<sup>th</sup> weather and Covid numbers cooperating. The practice will be masked

with social distancing. It is planned to have thrown weapons as well as a pell for fighters to practice and tables for arts and sciences work and projects. The practices will alternate between Hutchinson at Their Excellencies and Andover at Ulf's and Alia's.

There are several officers looking for deputies. It was noted that some are holding more than one office. Once the suspensions are eased these individuals will have more to do. Specifically needing a deputy are Seneschal, Exchequer, Archer Marshal, Web Minister, Arts and Sciences. There are others who could also use the assistance. Any interested individual should contact the officer. If a member knows of someone who might be interested please let the Seneschal or Their Excellencies know.

There being no other business the meeting adjourned.

## FINANCE MEETING—March 3, 2021

### Meeting held on the Zoom Platform

A meeting of the financial committee was held March 3, 2021 via ZOOM. Committee members present: Kris Griffith-Bumgardner/ HE Genèvieve de Chambery; Larry Bumgardner/ HE Lawrence Taillefer; Robert Botkin/ Ld. Robert the Scott; Kurt Jones/ Ld. Konrad von Roth; Mary J. Day/ HE Marie and Janie Hanes/ Frithuswith inghean Ui Cremthainn (Great Bend-Hays/Westumbria) representing the populace.

The bank signature card needs to be updated. The procedure and past policy history for this was discussed. It was recommended by the committee to contact the Regional Treasurer/ Exchequer for her advice. It was noted that the office would be changing soon due to the end of the current holder's tenure. She would best know the timetable for that change and can advise the how to proceed with the required paperwork.

There being no other business before the committee, the meeting adjourned.

Mary Day

Recording secretary



## THEIR ROYAL MAJESTIES

**LUCIAN & TAMAR**

Falcon-Crown@calontir.org



## UPCOMING KINGDOM EVENTS

**April**

*All Calontir SCA  
In person events  
Are suspended*

**May**

*All Calontir SCA  
In person events  
Are suspended*

**June**

*Lilies War  
June 12- June 19  
Calon Con  
June 26*

## BARONIAL GATHERINGS

**Populace Meeting** Third Wednesday, 7-9pm

**Zoom Meeting (See Current Vatavia Weekly Herald)**

**Fighter Practice** (Armored Combat and Calon Steel)

**In person practice cancelled**

For more information contact:

Lord Brynjolfr Falkason

knightmarshal@baronyofvatavia.org

**Archery Practice**

Sundays 10am-2pm—Alternating Hutchinson-Andover

**See Current Vatavia Weekly Herald**

For more information contact;

Lady Heidi Anne Draper

archermarshal@baronyofvatavia.org

**Officers' Meeting & Finance Meeting**

First Wednesday of the month, 7-9pm

Open to the populace.

**Zoom Meeting (See Current Vatavia Weekly Herald)**

**Arts and Sciences Gatherings** 1st, 2nd, and 4th  
Wednesday, 7-9pm

**Zoom Meeting (See Current Vatavia Weekly Herald)**

**Demos**

**All Demos are suspended until after May 31, 2021**

## TO GET A COPY OF THE KNOWN WORLD HANDBOOK

Contact His Lordship Friar Thomas

316-685-1182

Handbooks are \$23.00

# Catapults and Trebuchets

*By Baroness Marie Chantel Delaire*

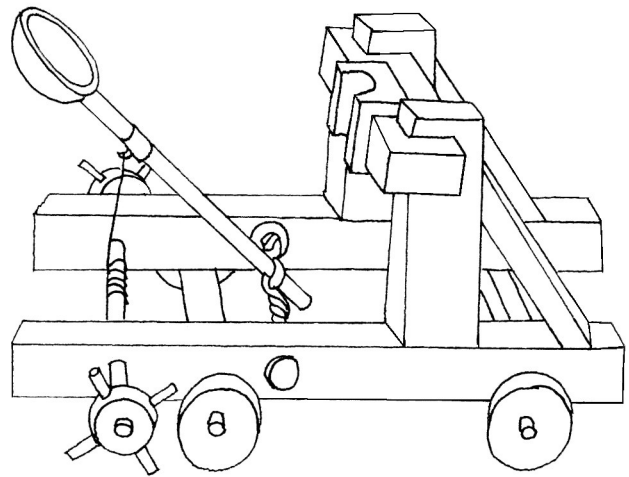

Crusaders brought knowledge of siege weapons back with them to Europe in the 1100's. However, such weapons had existed for centuries. The Roman Empire in the 3<sup>rd</sup>-4<sup>th</sup> century BCE had ballistas, developed from bows, and catapults. These used torsion from twisted materials to produce the throwing power. These used the stored potential energy in a sudden release. The violent stopping of the throwing arm of the catapult absorbed much of this energy. These weapons had the advantage of smaller, lighter size. They could be dismantled, transported and reassembled at the site. The disadvantage was the constant required maintenance. They often failed, could not be effectively aimed, had a straight trajectory and limited range. It required a good size firing team to operate the catapult.

Trebuchets came much later to Europe. The power source was traction produced by teams of men or a counterweight, instead of torsion. This type of weapon was simpler in design, more durable, and required fewer operators. Using the advantage of a longer lever, high elevation and a sling for the projectile produced considerable acceleration from the effects of gravity and the rotation of the lever producing an arcing trajectory. They provided greater range and heavier payloads. However they required more time to reload –only 3 to 4 shots a day, more time to construct and could not be transported. Building on site was common. Physics shows these need careful calibration for the correct counterweight (as much as 40 times the projectile weight), angle of release, and distance to target. To throw a 250 pound stone 600 feet would require a counterweight of 5-6 tons.

Trebuchets were first used in China in the 4<sup>th</sup> century BCE. The design was carried west into the Middle East by the Avars, Eur-Asian nomads, in the 6<sup>th</sup> century CE. These machines are recorded as being used in Byzantium in 587 CE, Islam 624 CE, by the Franks, Saxons and Russians in the 7<sup>th</sup> century CE, Scandinavia 873 CE. The first types used traction with teams of men pulling on the short end of the lever. A disadvantage was coordination of the pulling teams which was a challenge. A hybrid style came along that put weight directly on the shorter end of the trebuchet's lever allowing gravity to do the work. A 1187 military manual written by one of Saladin's engineers stated a hybrid trebuchet had the equivalent power of a 500 man team. The first solid reference to a counterpoise/ counterweight trebuchet is its use in 1199 at the siege of Castelnuovo Bocca d'Adda in Lombardy.

The name trebuchet is from the Middle French *trebuch* meaning to tumble, fall over. Several other names were given to these weapons. During the siege of 579 Archbishop John of Thessalonikes (Macedonia) called them *petrobolos*, city takers. In the 11<sup>th</sup> century in the Middle East it was referred to as *al-Ghadban*, the furious one. Several Italian nicknames are God's stone thrower, daughter of the earthquake, big mother and bad neighbor. The first English reference to a trebuchet was in the 14<sup>th</sup> century with the name *trepegete*. Perhaps the most famous named trebuchet is *Lupus Guerre*, the War Wolf.

It was built for the siege of Sterling Castle, April 22- July 24, 1304, for Edward I, the Hammer of the Scots. Little information exists about this trebuchet. There are no representations of it. It is believed to have been the largest weapon of its kind ever built. It was built on site with the materials being transported to the castle. What is known is that it took 30 wagons to haul the materials. The chief engineer, James of St. George, worked with 5 master carpenters, directing 49 workers for 3 months. It was the last weapon constructed. There were 12 to 17 (depending on the reference) other siege weapons used. They also had names; but, the name *Loup de Guerre*, or *Ludgar* as the Anglo-Saxon members called it, is the name that has come down through history.

There are references by chroniclers who were there about the siege and battles. But there are only two court records that actually mention the War Wolf by name: (translated from the Latin)

“To Master Alexandro le Convers, for money paid by him to the carpenters making the engine called Lupus Guerre, and other workers working in May and June 1304 10 shillings on 7 June 1304”

“To Thomas de Viridis Campus, the queen’s valet, recompensed at the King’s hand for his labors in the making of the Lupus Guerre, which the King ordered to be made to slight Stirling Castle £ 40”

And a third reference, but not mentioning the name: “...to Reginald the janitor for guarding its beams for 40 nights in June and July 1304”

The surrender of the Scots was denied on July 20<sup>th</sup>. Edward wanted to see the engine in action. When the garrison was allowed to surrender July 24<sup>th</sup> 30 defenders had survived. Witnesses wrote that the War Wolf demolished an entire section of the castle wall.

It is estimated the War Wolf stood 300 feet or more tall when the throwing arm was extended. It is believed that it threw the projectile about 200 yards at a speed of 120 mph. But by 1400’s the development of cannons and the increased use of gunpowder replaced the old siege engines. Smaller trebuchets still operated, but as troop support. Large trebuchets were still used when gunpowder was in short supply, which is the reason Hernando Cortéz built one for the attack on Tenochtitlán. Unfortunately a miscalculation had the first projectile land on the trebuchet destroying it.

Trebuchets have not totally disappeared from history. During the Great Siege of Gibraltar, June 24, 1779 to February 7, 1783 (the longest continuous siege in history) trebuchets replaced some of the cannons. They had greater distance and could reach the enemy ships and island locations that the cannons could not. Even recently small engines have been used by rioters in Kiev in 2012 and the Ukraine in 2014. They were used during the Battle of Aleppo in the Syrian Civil War in 2013. An ancient weapon that still has found uses in our current Middle Ages and the world.

<https://blog.stirlingcastle.scot/2018/11/21/war-wolf-siege/>

<https://www.vaguelyinteresting.co.uk/warwolf-and-the-hammering-of-the-scots/>

<https://danspencer.info/2018/11/10/the-siege-of-stirling-castle-in-1304>

<https://www.ucl.ac.uk/~zcapf71/Trebuchet%20coursework%20for%20website.pdf> \*75 pages

William Gurstelle **Popular Mechanics**  
5/1/2017 “Legend of Ludgar the War Wolf, King of the Trebuchets, Edward Longshanks Master Machine of Death”

DVD Codice Atlantico version 2.9 5/5/2006  
copyright Leonardo 3 Biblioteca Ambrosiana

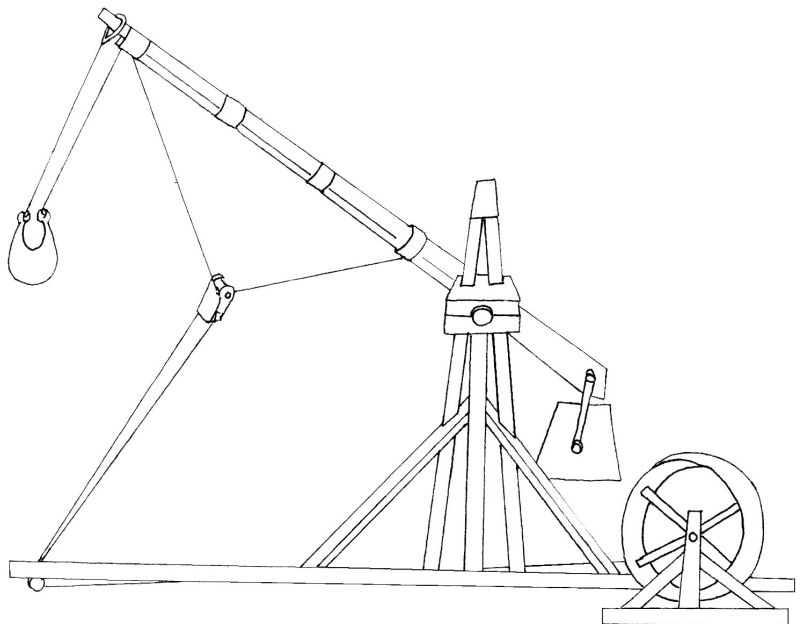

# Vatavian Arts and Science

**Amy Groom-Dyke**

## **Tablet Woven Trim**

12' exactly. Colors are purple/gold. Oseberg 12L1 on either side and Oseberg 21 down the center. The fringe still needs to be completed but it's off the loom. Took just over a month to finish working on it when I had time here and there.



**Lady Heidi Anne Draper (MKA Heidi Botkin)**

## **Spinning Wool**

Learning how to spin wool on a spinning wheel.

Beginning a new adventure in the fiber arts. I have always been allergic to wool, but through research, as well as trial and error, I have learned that I am allergic to how some of it is processed and treated in the United States. This discovery has allowed me to work with wool and learn a new skill.



**Lady Margaret MacKenzie  
(MKA Jayme Jones)**

**Bobbin Lace Pillow**

This is not a historical recreation of a period style bobbin lace pillow, but its function is to allow for yardage of bobbin lace to be made using it. The design is a cross between a Puerto Rican and a French bobbin lace pillows. Materials used to make it include pine boards, oak dowel, 3/8" high density foam, pipe insulation foam, denim, felt, cotton fabric, hardware, hot glue, double back tape, decorative trim, thin craft leather from Tandy & anti-slip foam.



# Medieval Olympics

## Backdrop Competition

### Lady Berke Chinua

(MKA Tammy Miller)

The center is the registered devise for our shire. Each picture around is a flag of a members persona.

Starting upper left Eynon, Wales ( no flag in period) Berke, Mongolia Felicia, Sweden , Elisa, Ireland Nagamitsu, Japan Second down/start left Astrid, Iceland ( they had no flag in period)



### Matthius Worchestershire

(MKA Benjamin Rogers)

My Banner for Scribarum Celebratio (The Celebration of Scribes), paint on sized linen.

Will hang outside of Scriptorium, once it is up and running.

Winner of populace choice—February competition



**HE Genevieve de Chambery  
(MKA Kristina Griffith)**

Banner—taken from the Manesse Codex— A manuscript of Songs and Poems 1304.

Hand drawn and painted on fabric. It is not completed yet. It still needs shading and details.



# April 2021

SUN	MON	TUE	WED	THU	FRI	SAT
				1	2	3
4	5	6	7 Officers' Meeting	8	9	10
11	12	13	14 A & S Glass Bead Making	15	16	17
18 Archery Practice	19	20	21 Populace Medieval Olympics Shadowbox	22	23	24
25 Archery Practice	26	27	28 Makers Meet-up	29	30	



# May 2021

SUN	MON	TUE	WED	THU	FRI	SAT
						1
2 Archery Practice	3	4	5 Officers' Meeting	6	7	8
9 Archery Practice	10	11	12 A&S—TBD	13	14	15
16 Archery Practice	17	18	19 Populace Medieval Olympics Trebuchet	20	21	22
23 Archery Practice	24	25	26 A&S—TBD	27	28	29
30	31					

# June 2021

<i>SUN</i>	<i>MON</i>	<i>TUE</i>	<i>WED</i>	<i>THU</i>	<i>FRI</i>	<i>SAT</i>
		1	2 Officers' Meeting	3	4	5
6 Archery Practice	7	8	9 A&S—TBD	10	11	12
13 Archery Practice	14	15	16 Populace	17	18	19
20 Archery Practice	21	22	23 A&S—TBD	24	25	26 Calon Con
27 Archery Practice	28	29	30 A&S—TBD			